

*This specification describes the situation of the Belgacom network and services. It will be subject to modifications for corrections or when the network or the services will be modified. The reader is requested to check with the most recent list of available specifications that the document in one's possession is the latest version.*

*Belgacom can't be held responsible for any damages due to the use of a version of this specification which is not included in the most recent list of available specifications.*

*Whilst every care has been taken in the preparation and publication of this document, errors in content, typographical or otherwise, may occur. If you have remarks concerning its accuracy, please write to "BELCOMLAB" at the address shown on the support page and your remark will be transmitted to the right Belgacom department.*

*The User Network Interface Specifications published via Internet are available for your information but have no official value. The only documents with an official value are printed on a specific paper.*

*If you want to get an official version of this User Network Interface Specification, please order it by sending your request to:*

*Belgacom / BELCOMLAB  
Rue Carlistraat 2  
B-1140 Evere  
Belgium*

*Tel: +32 2 244.58.88  
Fax: +32 2 244.59.99  
E-mail: [belcomlab@belgacom.be](mailto:belcomlab@belgacom.be)*

# ADSL over POTS

**Table of Contents**

- TABLE OF CONTENTS.....A**
- 1. PREFACE .....1**
- 2. SYSTEM REFERENCE MODEL .....2**
- 3. UNI .....3**
  - 3.1. Transport capacity .....3
  - 3.2. ATU-C Functional Characteristics .....3
  - 3.3. ATU-R Functional Characteristics .....3
  - 3.4. Operations and Maintenance .....3
  - 3.5. Initialisation .....3
  - 3.6. Online Adaptation and Reconfiguration .....4
  - 3.7. Electrical Characteristics .....4
  - 3.8. Performance requirements .....4
  - 3.9. Multi Mode Modem Support .....4
- 4. REFERENCES .....5**
- ANNEX A : LOCAL LOOP CHARACTERISTICS.....6**

## 1. Preface

The goal of this document is to provide the technical specifications of the User To Network Interface (UNI) for ADSL equipment to be connected to the Belgacom network.

As ADSL may provide a variety of bearer channels in conjunction with other services, this document deals with the ADSL service on the same pair with voice-band services (i.e. POTS or voiceband data services).

The UNI technical specifications for the ADSL service, mentioned in this document, are based on the currently relevant international recommendations for ADSL equipment; namely:

- \* The ITU-T G.992.1 Recommendation [1];
- \* The ITU-T G.994.1 Recommendation [2].
- \* The ANSI T1.413-1998 Standard [3];

## 2. System reference model

The system reference model for the *ADSL service* has been made in figure 1; it illustrates the functional blocks required to provide an ADSL service. This model is based on figure 1-1 of ITU-T Recommendation G.992.1 (section 5).

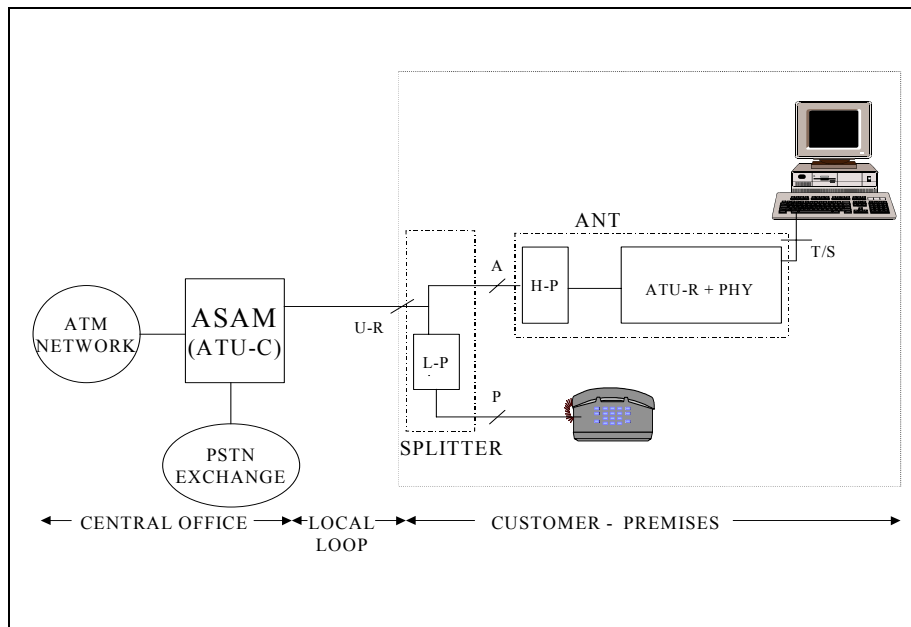

Fig. 1 : System reference model for ADSL service

The following main-building blocks can be distinguished :

- **ASAM** : the ATM Subscriber Access Multiplexer (including the ADSL transceiver unit at the central office; i.e. network operator);
- **ANT** : the ADSL network termination (which includes the ADSL transceiver unit at the remote terminal; i.e. customer premises);
- **splitter** : Filter that separates the high frequency signals (ADSL) from the voice-band signals (frequently called POTS splitter). As this document deals with the ADSL service on the same pair with voice-band services (including POTS and voiceband data services), a POTS splitter has to be used at customer premises. The splitter consists of a high-pass (H-P) and a low-pass (L-P) filter. In the reference model the high-pass filter has been integrated into the ANT; however, the high-pass filter may also be implemented externally to the ANT.
- **U-R** : The loop interface U-R carries the normal Plain Old Telephone Service (POTS) frequencies, multiplexed with the upstream and downstream ADSL signals. The upstream and downstream ADSL signals are DMT (Discrete Multi Tone) modulated.
- **ATU-C** : The ADSL transceiver unit at the Central Office side
- **ATU-R** : The ADSL transceiver unit at the remote end

### 3. UNI

The U-R-interface connects the ANT (with ATU-R) to the ASAM (with ATU-C) via the copper access network. Normal subscriber line wire is used for this connection.

Physically, the UNI – connection point is situated on the point **U-R** of the system reference model (see fig 1).

The sub – paragraphs mentioned below describe the ATU-R and ATU-C functionalities and requirements in order to establish an ADSL – connection.

The characteristics of the local loop are described in annex A.

#### 3.1. Transport capacity

- The transport capacity of the ATU-C complies with section 6 of ITU-T Recommendation G.992.1. It supports downstream transmission at all multiples of 32 Kbit/s up to a net data rate of 6.144 Mbit/s, and upstream reception at all multiples of 32 Kbit/s up to a net data rate of 640 Kbit/s.
- By consequence, the transport capacity of the connected ATU-R has to comply with section 6 of ITU-T Recommendation G.992.1 . It shall support downstream reception at all multiples of 32 Kbit/s up to a net data rate of 6.144 Kbit/s and upstream transmission at all multiples of 32 Kbit/s up to a net data rate of 640 kbit/s.

#### 3.2. ATU-C Functional Characteristics

The functional characteristics of the ATU-C comply with section 7 and ANNEX A.1 of ITU-T Recommendation G.992.1. The ATU-C complies with the ATU-C state diagram in ANNEX D of ITU-T Recommendation G.992.1

#### 3.3. ATU-R Functional Characteristics

The functional characteristics of the ATU-R shall comply with section 8 and ANNEX A.2 of ITU-T Recommendation G.992.1. The ATU-R shall comply with the ATU-R state diagram in ANNEX D of ITU-T Recommendation G.992.1.

#### 3.4. Operations and Maintenance

Regarding the operations and maintenance, the ATU-C complies with section 9 of ITU-T Recommendation G.992.1. The ATU-R shall comply with section 9 of ITU-T Recommendation G.992.1.

#### 3.5. Initialisation

The ATU-C complies with the initialization sequence as described in section 10 and ANNEX A.3 of ITU-T Recommendation G.992.1. The ATU-R shall comply with the initialization sequence as described in section 10 and ANNEX A.3 of ITU-T Recommendation G.992.1.

### 3.6. Online Adaptation and Reconfiguration

Regarding the online adaptation and reconfiguration, the ATU-C complies with section 11 of ITU-T Recommendation G.992.1. The ATU-R shall comply with section 11 of ITU-T Recommendation G.992.1.

### 3.7. Electrical Characteristics

The electrical characteristics of the ATU-C comply with ANNEX A.4 of ITU-T Recommendation G.992.1. The ATU-R shall comply with ANNEX A.4 of ITU-T Recommendation G.992.1.

### 3.8. Performance requirements

The ATU-R shall achieve the performance requirements listed in ITU-T Recommendation G.992.1 Table G.1.

### 3.9. Multi Mode Modem Support

The above mentioned sections 3.1 to 3.8 refer to ITU-T Recommendation G.992.1 for the ATU-R requirements for interoperation with the ATU-C. However, in addition to an ATU-R compliant with ITU-T Recommendation G.992.1, the ATU-C also supports fallback to interoperation with an ATU-R compliant with ANSI-T1.413-1998.

The ATU-C initialization procedure supports both the ITU-T Recommendation G.994.1 handshake procedures [3] and the ANSI T1.413-1998 [1] initialization procedure. The ATU-C provides auto-detection of an ATU-R compliant to either ANSI T1.413-1998 or ITU-T Recommendation G.992.1 or both.

In case the ATU-R supports both ANSI T1.413-1998 and ITU-T Recommendation G.992.1 and alternates related initialization and handshake procedures according to ITU-T Recommendation G.994.1 Annex A, then the ATU-C gives priority to the ITU-T Recommendation G.994.1 handshake procedures and a subsequent ITU-T Recommendation G.992.1 operating mode.

#### **4. References**

[1] ITU-T Recommendation G.992.1, "*Asymmetrical Digital Subscriber Line (ADSL) Transceivers*", published by ITU-T.

[2] ITU-T Recommendation G.994.1 "*Handshake Procedures for Asymmetrical Digital Subscriber Line (ADSL) Transceivers*", published by ITU-T.

[3] ANSI Standard T1.413-1998, "*Network and Customer Installation Interfaces – Asymmetrical Digital Subscriber Line (ADSL) Metallic Interface*", published by ANSI.

## ANNEX A : Local loop characteristics

A telecoms cable consists of a number of *cores* surrounded by a layer of insulating material. The cores of such a cable are always grouped in *pairs of conductors*.

Cables in the local network are designed so as to ensure optimum transmission and guarantee minimum mechanical resistance. For this reason, the description of cables below consists of a section dealing with electrical characteristics and one dealing with mechanical characteristics.

### *Mechanical characteristics*

- The conductors of a local cable are round, full wires consisting of 98%–99% pure electrolytic copper.
- A conductor is isolated by a layer of synthetic material (usually polyethylene).
- Most conductors have a 0.5 mm or 0.6 mm diameter with a maximum negative variance of 0.01 mm and a positive variance of 0.03 mm.
- The set of conductors is covered by a waterproof extruded cable sheath (usually polyethylene). Under normal circumstances, the cable is also longitudinally waterproof.
- The cable cores are arranged in a specific manner. The two conductors (e.g. of a telephone circuit) must be arranged symmetrically in relation to all other conductors. For this reason, conductors are twisted and placed in coaxial cylindrical layers (*a basic unit consists, for example, of four conductors twisted around one another and from which two telephone circuits can be created; a cross section shows that these four conductors form the corners of a square. The conductors located on two opposite angular points form a pair*).

### *Electrical characteristics*

- Since the signals to be transmitted are changeable electrical voltages, the cable conductor must be a good transmission medium for electrical signals. The important elements are defined for a unit length of one kilometer and are called primary electrical parameters of a conductor. These parameters are kilometer resistance R, kilometer inductance L, kilometer capacity C and kilometer leakance G.
  - ◆ kilometer resistance R
    - \* Kilometer resistance is the initial resistance of a one kilometer conductor pair that is looped at the remote end; the value of this parameter is therefore the resistance of a conductor with a length of two kilometers.
      - ⇒ R is 180 Ohm for a conductor diameter of 0.5 mm (at 20°C);
      - ⇒ R is 123 Ohm for a conductor diameter of 0.6 mm (at 20°C).
    - \* It should be noted that due to the skin effect, the alternating current resistance is higher than the direct current resistance indicated above.
  - ◆ kilometer inductance L
    - \* In a symmetrical pair cable, conductors forming a pair lie very close to one another; kilometer inductance L is therefore very low (approx. 0.5 mH per kilometer).

- ◆ kilometer capacity C
  - \* The capacity between two conductors of the same pair can be measured when the rest of the cable conductors are connected to each other and to an equipotential point of a measuring device. The nominal value of kilometer capacity C is situated between 38.5 nF/km and 50 nF/km at 800 Hz.
  
- ◆ kilometer leakance G
  - \* Kilometer leakance G depends on the frequency concerned and kilometer capacity C. Theoretically, kilometer leakance may be considered as negligible.
  - \* G can roughly be calculated with the help of the following formula, in which k has a value between 0.005 and 0.02 ( $\omega$  = pulsation in rad/s):

$$G = k \cdot \omega \cdot C$$

- The insulation resistance of each conductor in relation to the rest of the conductors (and any shielding) is at least 5,000 M $\Omega$ /km.