

**This specification** describes the situation of the Belgacom network and services. It will be subject to modifications for corrections or when the network or the services will be modified. Please take into account that modifications can appear at any moment. Therefore, the reader is requested to check regularly with the most recent list of available specifications that the document in one's possession is the latest version.

Belgacom can't be held responsible for any damages due to the use of a version of this specification which is not included in the most recent list of available specifications (list always available with a request to the e-mail address mentioned in the underneath paragraph).

Whilst every care has been taken in the preparation and publication of **this document**, errors in content, typographical or otherwise, may occur. If you have remarks concerning its accuracy, please send a mail to the following address [belgacom.uni.spec@belgacom.be](mailto:belgacom.uni.spec@belgacom.be) and your remark will be transmitted to the right Belgacom department.

The User Network Interface Specifications published via Internet are available for your information but have no official value. The only documents with an official value are printed on a specific paper.

If you want **to get an official version of this User Network Interface Specification**, please order it by sending your request by mail to [belgacom.uni.spec@belgacom.be](mailto:belgacom.uni.spec@belgacom.be)

# **The Belgacom Private ONNET Service**

## Table of Contents

<b>0.</b>	<b>DOCUMENT HISTORY .....</b>	<b>1</b>
<b>1.</b>	<b>INTRODUCTION.....</b>	<b>2</b>
<b>2.</b>	<b>REFERENCE MODEL .....</b>	<b>3</b>
<b>3.</b>	<b>ISDN INTERFACE AND TRANSMISSION CHARACTERISTICS – BA &amp; PRA.....</b>	<b>4</b>
<b>4.</b>	<b>PROTOCOL SPECIFICATIONS FOR THE BA AND PRA INTERFACE.....</b>	<b>6</b>
4.1.	References.....	6
4.2.	Symbols, definitions and abbreviations .....	7
4.3.	Supported services for the Q.931 protocol .....	8
4.4.	Additional information .....	9
<b>ANNEX A : STANDARD NETWORK TIMERS FOR THE BASIC ACCESS INTERFACE .....</b>		<b>11</b>
<b>ANNEX B : STANDARD NETWORK TIMERS FOR THE PRIMARY RATE ACCESS INTERFACE. ....</b>		<b>12</b>

## 0. Document history

Every update of this document results in a complete new version with new version number and release date.

Version	Date	Main or important changes since previous version
1.0	25 FEB 2002	<ul style="list-style-type: none"><li>• First version</li></ul>

## 1. Introduction

The present document specifies the interface, transmission characteristics and protocol specifications of the ISDN User Interface offered on Belgacom Private ONNET Service for local powered terminals.

For this moment, the Layer 3 protocol is limited to Q.931 only. Q-SIG specifications will be added later.

Access to the Belgacom Private ONNET Service is possible via a user-network interface, which has been fully defined in international ITU-T and ETSI recommendations.

The customer has the choice between two types of access, namely:

- Basic access (BA);
- Primary Rate Access (PRA).

Paragraph 2 of this document contains the Reference Model for the two ISDN access interfaces mentioned above.

Paragraph 3 describes the transmission characteristics of ISDN connections.

Paragraph 4 describes the protocol specifications of the ISDN access interfaces.

## 2. Reference Model

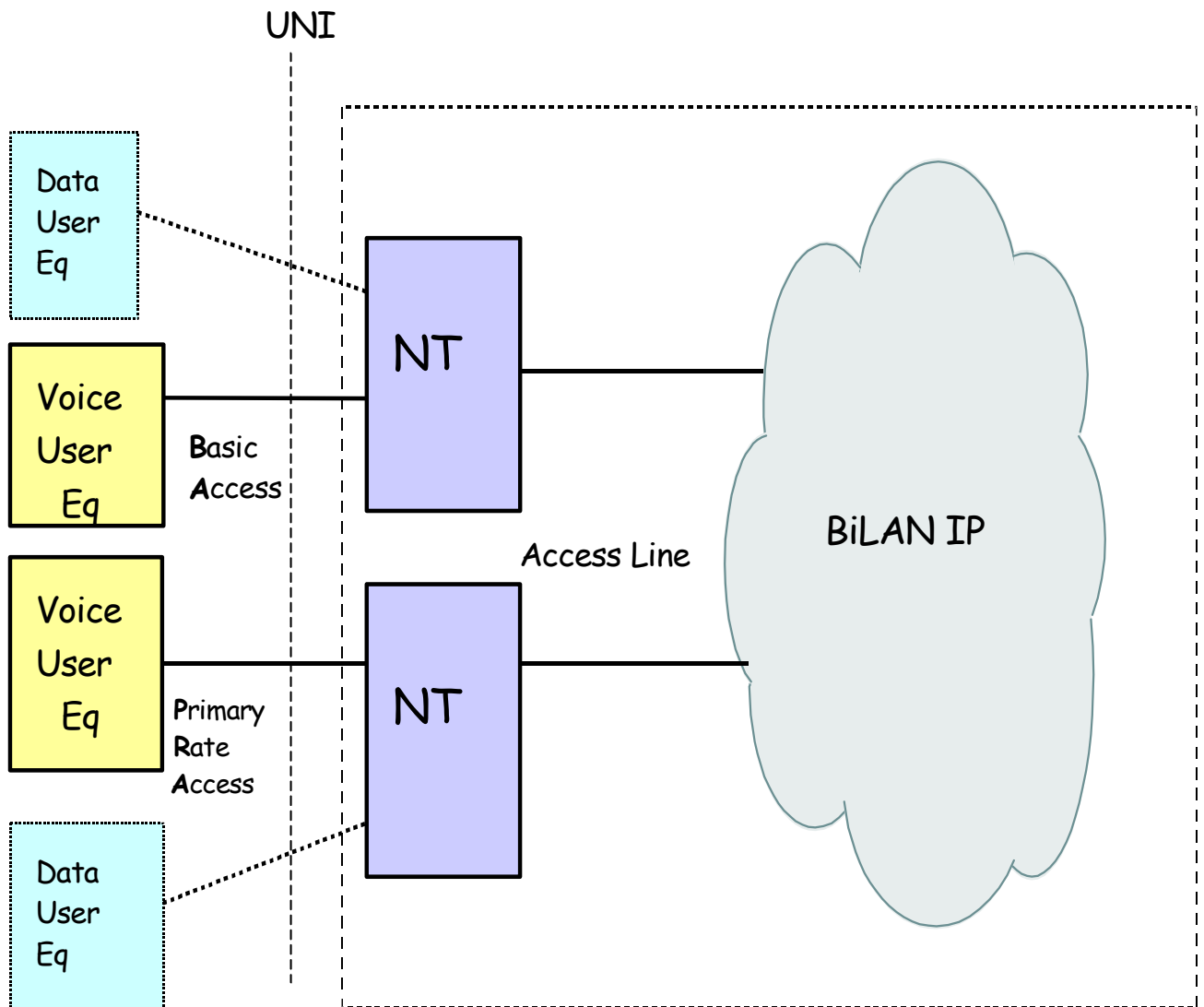

Figure 1: Belgacom Private ONNET Service - UNI reference model

### 3. ISDN Interface and Transmission characteristics – BA & PRA

The ISDN interfaces are built up according to the relevant ITU-T and ETSI specifications. The interface points are specified according to ITU I.411, including the T interface.

The equipment and network termination points are defined in the context of the 7 layers OSI model, whereby only the three lower layers are used for the network part of it:

- Physical Layer
- Data Link Layer
- Network Layer

Overview Applied interfaces with their specifications

	BA	PRA
Layer 1	ETS 300 012	ETS 300 011
Layer 2	EN 300 402	EN 300 402
Layer 3	EN 300 403	EN 300 403

**Restriction on the Basic Access interface: the user can connect only local powered devices (e.g. PABX, routers, PC boards) because the Basic Access interface has no power source.**

The principal characteristics of the ISDN interfaces are:

	BA	PRA
Number of B-channels	2	30
Number of D-channels	1	1
Synchronisation	8 kbps	64 kbps (channel 0)
Bit rate B-channel	64 kbps	64 kbps
Bit rate D-channel	16 kbps	64 kbps (channel 16)
T-interface 4 wire	4 wire -100 Ohm female RJ45 connector Transmit 3-6 Receive 4-5	4 wire 120 Ohm female RJ45 connector Receive 1-2 Transmit 4-5
PS1 Power Normal & Restricted Power	<b>Not provided</b> <b>Only local powered terminals</b> <b>can be connected</b>	Na
CRC4 procedure	Na	<b>Procedure CRC4 may or may</b> <b>not be activated.</b> <b>Default is CRC4 ON</b>
Related interface specs	I.430 ETS 300 012	I.431 G.703/G.704 and G.706 ETS 300 011

## Details of the pole numbering on the interfaces.

### Basic Access

Pin Number	Contact	Network interface	Terminal interface	Signal Polarity
1	a	Not used	Not used	
2	b	Not used	Not used	
3	c	Transmit	Receive	+
4	d	Receive	Transmit	+
5	e	Receive	Transmit	-
6	f	Transmit	Receive	-
7	g	Not used	Not used	
8	h	Not used	Not used	

### Primary Rate Access

Pin Number	Contact	Network interface	Terminal interface
1	a	Receive	Transmit
2	b	Receive	Transmit
3	c	Not Used	Not Used
4	d	Transmit	Receive
5	e	Transmit	Receive
6	f	Not used	Not used
7	g	Not used	Not used
8	h	Not used	Not used

## 4. Protocol specifications for the BA and PRA interface

### 4.1. References

The following documents contain provisions that, through reference in this text, constitute provisions of the present document.

- References are either specific (identified by date of publication, edition number, version number, etc...) or non-respect.
- For a specific reference, subsequent revisions do not apply.
- For a non-specific reference, the latest version applies.
- A non-specific reference to an ETS shall also be taken to refer to later versions published as an EN with the same number.

Specification	Short description of the specification
ETS 300 012	Integrated Services Digital Network (ISDN); Basic User-Network Interface (UNI); Layer 1 Specification and Test principles
ETS 300 011-1	Integrated Services Digital Network (ISDN); Primary rate User- Network Interface (UNI); Part 1: Layer 1 specification
ETS 300 402	Integrated Services Digital Network (ISDN); Digital Subscriber Signalling System No. one (DSS1) protocol; Data link layer; Part 1: General aspects [ITU-T Recommendation Q.920 (1993), modified]
EN 300 403-1	Integrated Services Digital Network (ISDN); Digital Subscriber Signalling System No. one (DSS1) protocol; Signalling network layer for circuit-mode basic call control; Part 1: Protocol specification specification [ITU-T Recommendation Q.931(1993), modified]
ETS 300 092-1	Integrated Services Digital Network (ISDN); Calling Line Identification Presentation (CLIP) supplementary service; Digital Subscriber Signalling System No. one (DSS1) protocol; Part 1: Protocol specification
ETS 300 093-1	Integrated Services Digital Network (ISDN); Calling Line Identification Restriction (CLIR) supplementary service; Digital Subscriber Signalling System No. one (DSS1) protocol; Part 1: Protocol specification
ETS 300 094	Integrated Services Digital Network (ISDN); Connected Line Identification Presentation (COLP) supplementary service; Service description
ETS 300 095	Integrated Services Digital Network (ISDN); Connected Line Identification Restriction (COLR) supplementary service; Service description
ETS 300 182-1	Integrated Services Digital Network (ISDN); Advice of Charge (AOC) supplementary service; Digital Subscriber Signalling System No. One (DSS1) protocol; Part1: Protocol specification
ETS 300 286	Integrated Services Digital Network (ISDN); User-to-User Signalling (UUS) supplementary service; Digital Subscriber Signalling System No. one (DSS1) protocol; Part 1: Protocol specification
ETS 300 064	Integrated Services Digital Network (ISDN); Direct Dialling In (DDI) supplementary service; Digital Subscriber Signalling System No. one (DSS1) protocol; Part 1: Protocol specification.

Specification	Short description of the specification
ETS 300 061	Integrated Services Digital Network (ISDN); Subaddressing (SUB) supplementary service; Digital Subscriber Signalling System No. one (DSS1) protocol; Part 1: Protocol specification
ETS 300 286	Integrated Services Digital Network (ISDN); User-to-User Signalling (UUS) supplementary service; Digital Subscriber Signalling System No. one (DSS1) protocol; Part 1: Protocol specification
ITU-T G.703	Physical/electrical characteristics of hierarchical digital interfaces
ITU-T G.704	Synchronous Frame structures used at 1455, 6312, 2048, 8448 and 44.736 kbits/s Hierarchical Levels
ITU-T G.706	Frame alignment and cyclic redundancy check (CRC) procedures relating to basic frame structures defined in Recommendation G.704

#### 4.2. Symbols, definitions and abbreviations

For the purpose of the present document, the following definitions applies:

AOC	Advice Of charging
AOC_E	Advice Of charging End
AOC_S	Advice Of charging Setup
BA	Basic Access
BiLan	<b>BELGACOM</b> Interconnection of <b>Local area Networks</b>
CLIP	Calling Line Presentation
CLIR-T	Calling Line Presentation Temporary
CNIP	Calling Name Presentation
COLP	Connected Line Presentation
COLR-T	Connected Line Presentation Temporary
CRC4	Cyclic Redundancy Check 4
DSS1	Digital Subscriber Signalling System No. one
EN	European Telecommunication Standard
ETS	European Telecommunication Standard
ISDN	Integrated Services Digital Network
ITU -T	International Telecommunication Union - Telecommunication sector
PRA	Primary Rate Access
PS1	Power Source 1 (Phantom power)
SUB	Sub Addressing
UUS1	User To User Info 1

#### 4.3. Supported services for the Q.931 protocol

Following ISDN PABX services will be available on BA and PRA interfaces :

Service	BA	PRA
CLIP	Supported	Supported - Note 1
CLIR-T	Supported – Note 1	Supported
COLP	Supported	Supported - Note 2
COLR-T	Supported – Note 2	Supported
SUB	Supported	Supported
UUS1	Supported	Supported
CRC4	Not Applicable	On Demand default is CR-4 on
Reduced Channel Capacity fraction of the 2 Mbit	Not Applicable	On Demand
Speech / 3.1 kHz Audio calls	Supported	Supported
64 kbit/s Unrestricted Digital Info	Supported	Supported
High Layer Compatibility	Supported	Supported
Low Layer Compatibility	Supported	Supported
CNIP via Display Info element	Supported	Supported
Display I.E. in the call Control Msg	Supported	Supported
Notify msg during conversation phase	Supported	Supported
Facility I.E. in the call Control Msg (example CCBS, AOC)	Supported	Supported

##### Note 1

The Calling Party Number I.E. is Full transparent :

Type of number:	Transparent	Advice : national number
Numbering plan id Advice:	Transparent	Advice : ISDN/Telephony numbering plan
Presentation ind:	Transparent	
Screening ind:	Transparent	Advice : user-provided, not screened
Calling Number	Transparent	Advice : national number

##### Note 2

The Connected Number I.E is Full transparent :

Type of number:	Transparent	Advice : national number
Numbering plan id	Transparent	Advice : ISDN/Telephony numbering plan
Presentation ind	Transparent	
Screening ind:	Transparent	Advice : user-provided, not screened
Connected Number	Transparent	Advice : national number

#### 4.4. Additional information

- Overlap sending is possible on PRA
  - Dial tone is not sent by the network in case of overlap sending, in the first phase
- Overlap sending is not possible on BA in the first phase of ONNET
- En block sending is possible on BA & PRA
- By default the network will be send a Channel I. E. with the indication :  
Preferred/exclusive field = 1 (exclusive: only the indicated channel is acceptable)
- Channel negotiation is possible (BA & PRA) if the user sent a Channel I.E. in the Setup msg
- The network sends ringing Back Tone on the BA interface to the Calling user (PRA later)
- Facility msg during the conversation phase is ignored
  - AOC information cannot be sent via the facility msg
  - AOC information can only be sent via the facility Info Element that is part of a call control Message (Setup, Connect, Disconnect, Release msg) = AOC\_S and AOC\_E.
- Facility msg in idle state is ignored
- High Layer Compatibility (HLC) Info Element is full transparent
- Low Layer Compatibility (LLC) Info Element is full transparent
- Bearer Capability Info Element is not fully transparent :
  - Following octets are transparent :
    - octet 3 (coding standard & information transfer capability)
    - octet 4 (transfer mode & information transfer rate)
  - Following octet has a default setting:
    - octet 5 (user information Layer 1 protocol) is default set to A law in case of BC= Speech or 3.1 kHz Audio
  - Following octets are ignored :
    - octet 4a (structure & configuration & establishment),
    - octet 4b (symmetry information transfer rate (destination → origination))
    - octet 5a (synch./asynch. & negot. user rate)
    - octets 5b & 5c (parameters for rate adaption V.110/X.30 or V.120)
    - octet 5d (duplex mode & modem type)
    - octet 6 (user information Layer 2 protocol)
    - octet 7 (user information Layer 3 protocol)

- The default data link setting is Point to Point (Fixed TEI 0-63) and is **default set to 0**.
  - The network can be configured for using a TEI between 0 – 63
    - user can be subscribed for a TEI different to 0 also.
- Point to Multi Point Data link (automatic TEI assignment 64-126) **is supported on the Basic Access interface on Subscription basis** in a physical Point to Point configuration (only one terminal connection is allowed)
- Point to Multi Point on layer 1 is not supported
- The parameters of the Called Party Number I.E. default are presented as follows :

Type of number:	national number
Numbering plan id Advice :	ISDN/Telephony numbering plan
Screening ind.:	user-provided, not screened
Called Number:	national number without the leading Zero

## Annex A : Standard Network timers for the Basic Access interface

ISDN BRI1/1 Timers (dsl 1) Switch type = basic-net3  
\*\*\* interface Network side configuration \*\*\*

### ISDN Layer 2 values

K = 1 outstanding I-frames  
N200 = 3 max number of retransmits  
N202 = 2 max number of TEI ID Request retransmits  
T200 = 1.000 seconds  
T202 = 2.000 seconds  
T203 = 10.000 seconds

### ISDN Layer 3 values

T302 = 10.000 seconds  
T303 = 4.000 seconds  
T304 = 30.000 seconds  
T305 = 30.000 seconds  
T306 = 30.000 seconds  
T307 = 180.000 seconds  
T308 = 4.000 seconds  
T309 = 90.000 seconds  
T310 = 30.000 seconds  
T312 = 6.000 seconds  
T313 = 4.000 seconds  
T316 = 120.000 seconds  
T318 = 4.000 seconds  
T319 = 4.000 seconds  
T321 = 40.000 seconds  
T322 = 4.000 seconds  
T300S = 5.000 seconds  
TGUARD = 3.000 seconds, Expiry = REJECT\_CALL

## Annex B : Standard Network timers for the Primary Rate Access interface

ISDN Serial1/0:15 Timers (dsl 0) Switch type = primary-net5  
\*\*\* interface Network side configuration \*\*\*

### ISDN Layer 2 values

K = 7 outstanding I-frames  
N200 = 3 max number of retransmits  
T200 = 1.000 seconds  
T202 = 2.000 seconds  
T203 = 10.000 seconds

### ISDN Layer 3 values

T303 = 6.000 seconds  
T304 = 30.000 seconds  
T305 = 30.000 seconds  
T306 = 30.000 seconds  
T307 = 180.000 seconds  
T308 = 6.000 seconds  
T309 = 90.000 seconds  
T310 = 40.000 seconds  
T313 = 6.000 seconds  
T316 = 120.000 seconds  
T318 = 4.000 seconds  
T319 = 4.000 seconds  
T322 = 4.000 seconds  
T300S = 5.000 seconds  
TGUARD = 8.000 seconds , Expiry = REJECT\_CALL