

This specification describes the situation of the Belgacom network and services. It will be subject to modifications for corrections or when the network or the services will be modified. Please take into account that modifications can appear at any moment. Therefore, the reader is requested to check regularly with the most recent list of available specifications that the document in one's possession is the latest version.

Belgacom can't be held responsible for any damages due to the use of a version of this specification which is not included in the most recent list of available specifications (list always available with a request to the e-mail address mentioned in the underneath paragraph).

Whilst every care has been taken in the preparation and publication of **this document**, errors in content, typographical or otherwise, may occur. If you have remarks concerning its accuracy, please send a mail to the following address belgacom.uni.spec@belgacom.be and your remark will be transmitted to the right Belgacom department.

The User Network Interface Specifications published via Internet are available for your information but have no official value. The only documents with an official value are printed on a specific paper.

If you want **to get an official version of this User Network Interface Specification**, please order it by sending your request by mail to belgacom.uni.spec@belgacom.be

STM-4 and VC-4-4c digital leased lines

Ref : BGC_D_48_0212_20_01_E.DOC

Version: 1.0 of 10TH December 2002

Page A

STM-4 and VC-4-4c digital leased lines

Table of Contents

0.	DOCUMENT HISTORY	1
1.	INTRODUCTION.....	2
2.	CONNECTION CHARACTERISTICS	4
2.1.	Common characteristics of STM-4 (4 VC-4 into 1 STM-4) and VC-4-4c (1 VC-4-4c into 1 STM-4) leased line connections.....	4
2.1.1.	Tolerance of VC timing	4
2.1.2.	Transfer delay for VC-4	4
2.1.3.	Transfer delay for VC-4-4c	4
2.1.4.	Jitter	4
2.2.	Specific characteristics of a STM-4 (4VC-4 into 1 STM-4) leased line connection.....	5
2.2.1.	Information transfer susceptibility	5
2.2.2.	Performance objectives	5
2.3.	Specific characteristics of a VC-4-4c (1 VC-4-4c into 1 STM-4) leased line connection ...	6
2.3.1.	Information transfer susceptibility	6
2.3.2.	Performance objectives	7
3.	THE NTP (STM-4 INTERFACE).....	8
3.1.	Physical section layers	8
3.1.1.	STM-4 optical interface	8
3.2.	STM-4 regenerator and multiplex section layers	9
3.3.	Path layer functions	10
3.4.	Safety	10
3.5.	ElectroMagnetic Compatibility (EMC).....	10
3.6.	TU/VC numbering scheme	11
4.	TERMINAL EQUIPMENT	12
ANNEX 1	13	
ANNEX 2	14	

0. Document history

Every update of this document results in a complete new version with new version number and release date.

Version	Date	Main or important changes since previous version
1.0	10 DEC 2002	<ul style="list-style-type: none">• First version

1. Introduction

This document contains the *technical specifications* for the Belgacom STM-4 (4 VC-4 into 1 STM-4) and VC-4-4c (1 VC-4-4c into 1 STM-4) digital leased line services.

The digital leased line provides a bidirectional point-to-point digital connection within a STM-4 frame in accordance with ITU-T Recommendation G.707.

The network interface presentation offered to a STM-4 (4 VC-4 into 1 STM-4) and a VC-4-4c (1 VC-4-4c into 1 STM-4) leased lines customer is based on the G957-interface.

The rules applied by BELGACOM for interfacing the customer's equipment with the BELGACOM SDH network are based on the G.707 and G.957 ITU-T recommendations. Only Optical interfaces are available. The network cabling follows the standard Belgacom rules.

These leased line specifications are based on a generic model as shown in figure 1.

The SDH connection is presented to the customer via an "interface presentation" at the Network Termination Point (NTP) which comprises all physical connections and their technical access specifications that form part of the Belgacom SDH leased line network.

This connection includes a series of SDH sections, providing the point-to-point transfer of signals between the terminal equipment of the customer.

The NTP is also the point at which the terminal equipment of the customer is attached to the SDH leased line offering an STM-4 interface; the attachment requirements for the customer's terminal equipment are also mentioned in this document.

The STM-4 (4 VC-4 into 1 STM-4) digital leased line service can be offered everywhere in the SDH Belgacom network. The VC-4-4c (1 VC-4-4c into 1 STM-4) digital leased line service can only be offered in the Belgacom ZTC and LTC where MSH51c or MSH64 are installed.

Throughout this document, reference is made to several national and international standards; details of these publications are given in annex 2. In addition, the list of the abbreviations which apply to this document, can be found in annex 1.

**Generic model for
STM-4 and VC-4-4c Leased
Line Specifications**

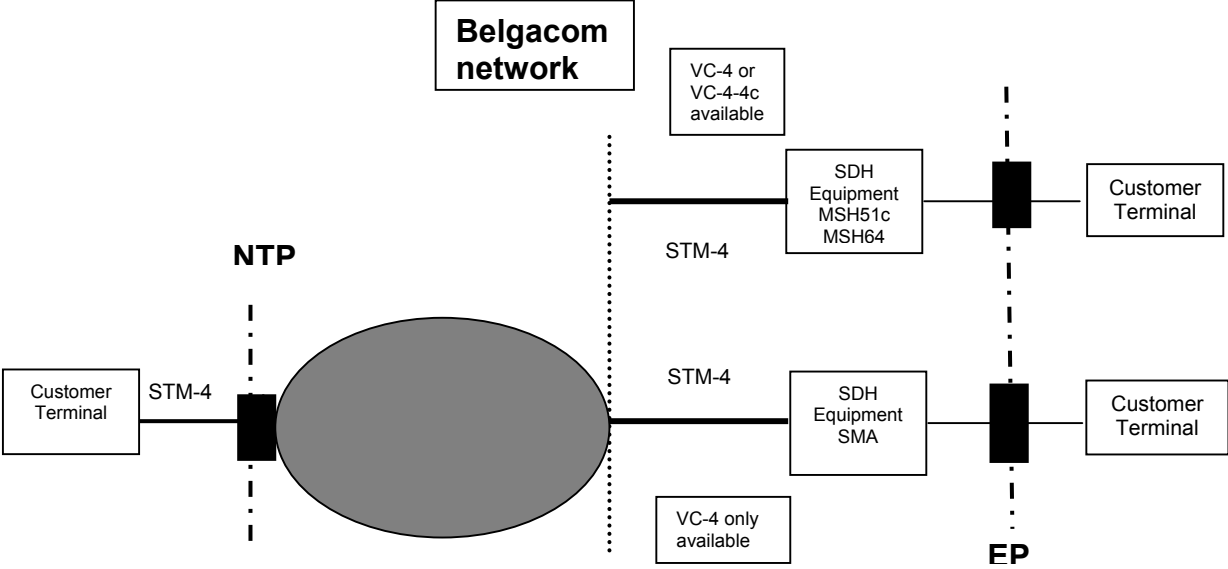

Figure 1

The drawing represents a point-to-point digital leased lines service.

2. Connection characteristics

The STM-4 (4 VC-4 into 1 STM-4) and VC-4-4c (1 VC-4-4c into 1 STM-4) SDH leased line provide a bi-directional and symmetrical leased line connection of SDH virtual containers, i.e. VC-4 and VC-4-4c, which are transferred transparently throughout the Belgacom network, except the N1 bytes.

Signals transmitted across the SDH leased line connections, are subject to restrictions and to impairments such as transfer delay, jitter, wander, etc. This paragraph defines the technical specifications for the bi-directional and symmetrical leased line connections of SDH virtual containers VC-4 and VC-4-4c.

2.1. Common characteristics of STM-4 (4 VC-4 into 1 STM-4) and VC-4-4c (1 VC-4-4c into 1 STM-4) leased line connections

2.1.1. Tolerance of VC timing

The SDH leased line connection shall carry the customer timing with a tolerance of ± 20 ppm (G.783).

2.1.2. Transfer delay for VC-4

The one way end-to-end delay of the SDH leased line is less than $(10 + 0,005G)$ ms, where G is the length of the optical fibres in kilometers. If this length is unknown, the one way end-to-end delay of the SDH leased line is less than $(10 + 0,01G)$ ms, where G is the geographical distance in kilometers.

2.1.3. Transfer delay for VC-4-4c

The one way end-to-end delay will be less than 250 ms.

2.1.4. Jitter

The SDH leased line connection shall operate as specified in this document when the jitter at the leased line input is within the limits given in paragraph 3 ("Network interface presentation").

2.2. Specific characteristics of a STM-4 (4VC-4 into 1 STM-4) leased line connection

2.2.1. Information transfer susceptance

- The STM-4 (4VC-4 into 1 STM-4) leased line connection shall be capable of transferring transparently from 1 to 4 complete bi-directional VC-4 except the N1-byte, provided that the VC-4 is generated according to the specifications mentioned in paragraph 4 (“terminal equipment”).
- The structure of a VC-4 is shown in figure 2. The bytes of a VC-4 are transmitted with a frequency of 8 kHz; i.e. the frame length is 125 μs.

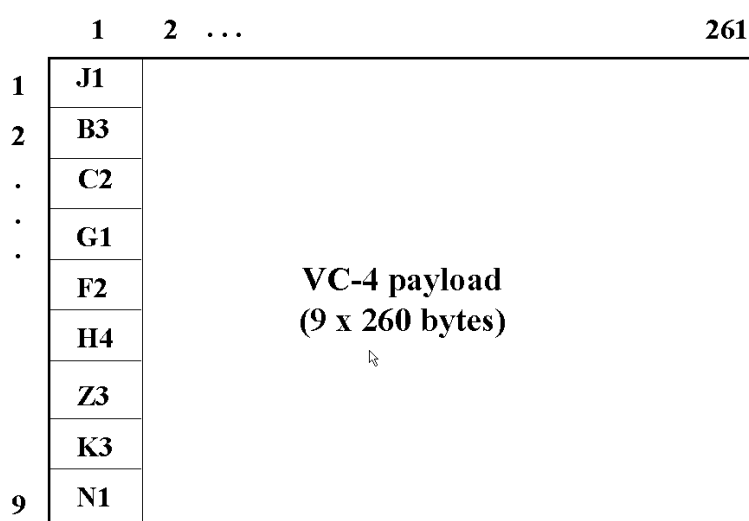

Figure 2

Note: the content of the B3 byte may change at Belgacom tandem connection monitoring processes; however, the integrity of B3 parity information is maintained through the VC-4 leased line connection.

- An AU-4-AIS shall occur at the far end output of the VC-4 leased line connection when a defect occurs along the SDH leased line connection or at the leased line input. [AU-4-AIS is a STM-N signal in which the entire capacity of an Administrative Unit 4 (AU-4) is set to logic “1”.]

2.2.2. Performance objectives

- The error performance level of a VC-4 leased line connection is specified in terms of errored seconds, severely errored seconds and background block errors; these performance parameters are as those defined in ITU-T Recommendation G.826.

2.3. Specific characteristics of a VC-4-4c (1 VC-4-4c into 1 STM-4) leased line connection

2.3.1. Information transfer susceptance

- The VC-4-4c (1 VC-4-4c into 1 STM-4) leased line connection shall be capable of transferring transparently 1 complete bi-directional VC-4-4c except the N1-bytes, provided that the VC-4-4c is generated according to the specifications mentioned in paragraph 4 (“terminal equipment”).
- The structure of a VC-4-4c is shown in figure 3. The bytes of a VC-4-4c are transmitted with a frequency of 8 kHz; i.e. the frame length is 125 μs.
- In the figure 3, N=4, X=4.

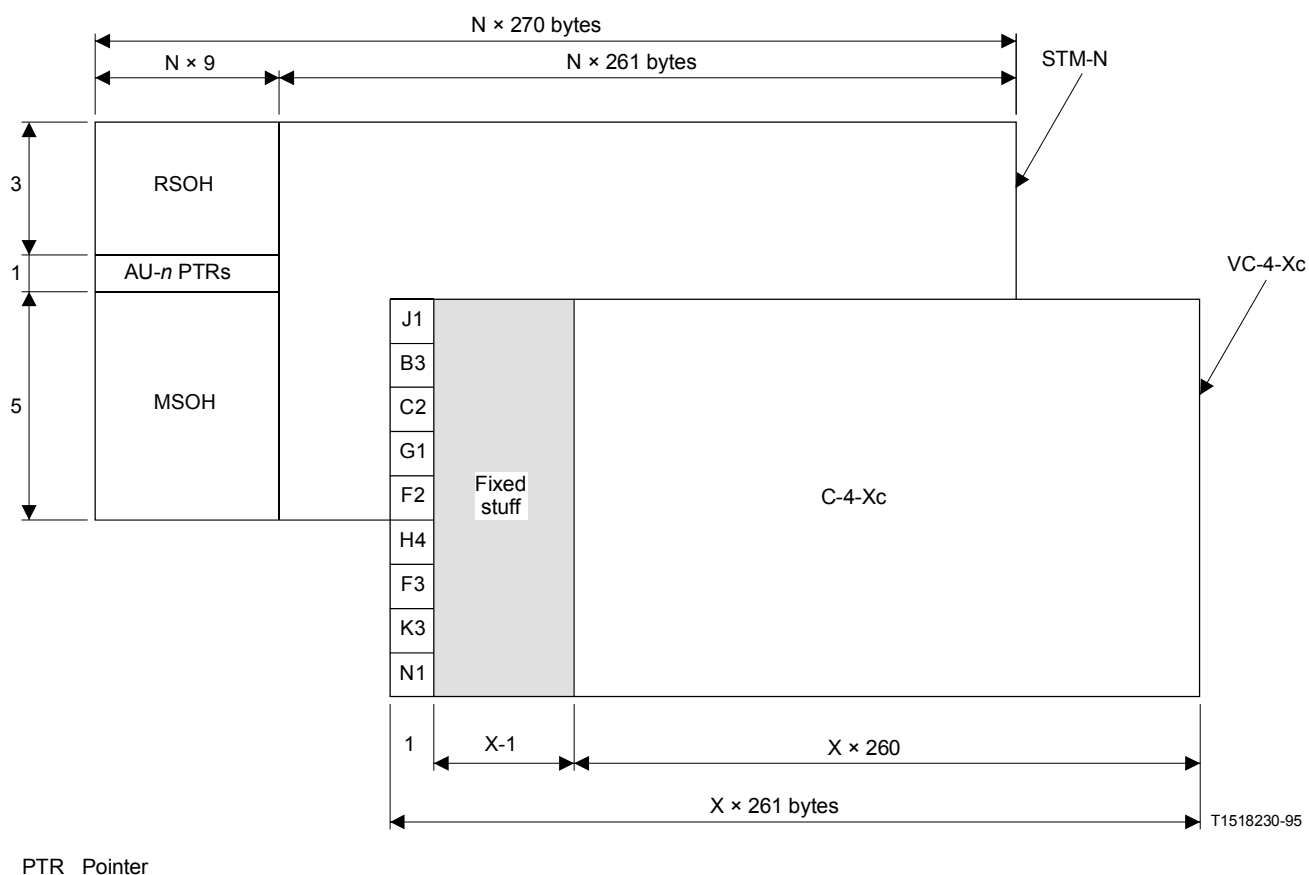

Figure 3

Note: the content of the B3 byte may change at Belgacom tandem connection monitoring processes; however, the integrity of B3 parity information is maintained through the VC-4-4c leased line connection.

- An AU-4-4c-AIS shall occur at the far end output of the VC-4-4c leased line connection when a defect occurs along the SDH leased line connection or at the leased line input. [AU-4-4c-AIS is a STM-N signal in which the entire capacity of a AU-4-4c is set to logic “1”.]

2.3.2. Performance objectives

- The error performance level of a VC-4-4c leased line connection is specified in terms of errored seconds, severely errored seconds and background block errors; these performance parameters are as those defined in ITU-T Recommendation G.826. Network interface presentation.

3. The NTP (STM-4 interface)

The SDH leased line connection is presented to the customer via interfaces at the Belgacom Network Termination Points (NTP). This paragraph specifies the NTP technical characteristics; it defines its specifications for the physical section layer, the regenerator & multiplex section layers, and the SDH path layers.

In principle, the NTP of the SDH leased line will be provided with a STM-4 interface, complying with the ITU-T Recommendations G.707 and G.783.

3.1. Physical section layers

The NTP of the SDH leased line shall be provided with one STM-4 optical interface.

3.1.1. STM-4 optical interface

- The optical characteristics of the SDH leased line NTP, equipped with a STM-4 optical interface, are in accordance with ITU-T Recommendation G.957; this SDH leased line NTP interface is designed for operation on *single-mode* optical fibres.
- The jitter and wander tolerance of the SDH leased line input port, as well as the output jitter and wander generation at the NTP are in accordance with ITU-T Recommendations G.825 & G.783.
- The SDH leased line NTP, equipped with an optical STM-4 interface, shall be provided with two optical sockets, one each for transmit and receive.

The STM-4 boards are connected to the optical fibre. This fibre is terminated onto an optical distribution frame (OSDF, OMDF or cable head).

The optical connectors that have to be mounted on the fibre cord relaying the optical distribution frame are of the type optoclip 2.

The Optoclip 2 connectors have the following characteristics:

- attenuation (25°C) :
 - Less than to 0.3 dB.
 - Mean value (measurement on more than 10 samples): < 0.25 dB.
 - After 200 connections/disconnections (15°<T<35°): < 0.4 dB and mean value (measurement on more than 10 samples): < 0.35 dB.
- Return loss :
 - More than 50 dB.
 - Mean value (measurement on more than 10 samples): more than 54 dB.
- Thermal behaviour :
 - Variation in attenuation between -20°C and 50°C: less than 0.004 dB/°C.
 - Mean value (measurement on more than 10 samples): < 0.003 dB/°C.

3.2. STM-4 regenerator and multiplex section layers

- As the STM-4 signal of the SDH leased line network interface complies also with ITU-T Recommendation G.707, regenerator and multiplex Section OverHead (SOH) information is added to the customer's information payload to create the STM-4 signal.

The rows 1-3 of the SOH are designated as Regenerator Section OverHead (RSOH) while rows 5-9 are designated to be Multiplex Section OverHead (MSOH). This is illustrated in figure 4. The definitions of the SOH bytes (such as A1, A2, JO,...) are mentioned in ITU-T Recommendation G.707.

Currently, the unmarked bytes in the SOH of figure 4, are undefined.

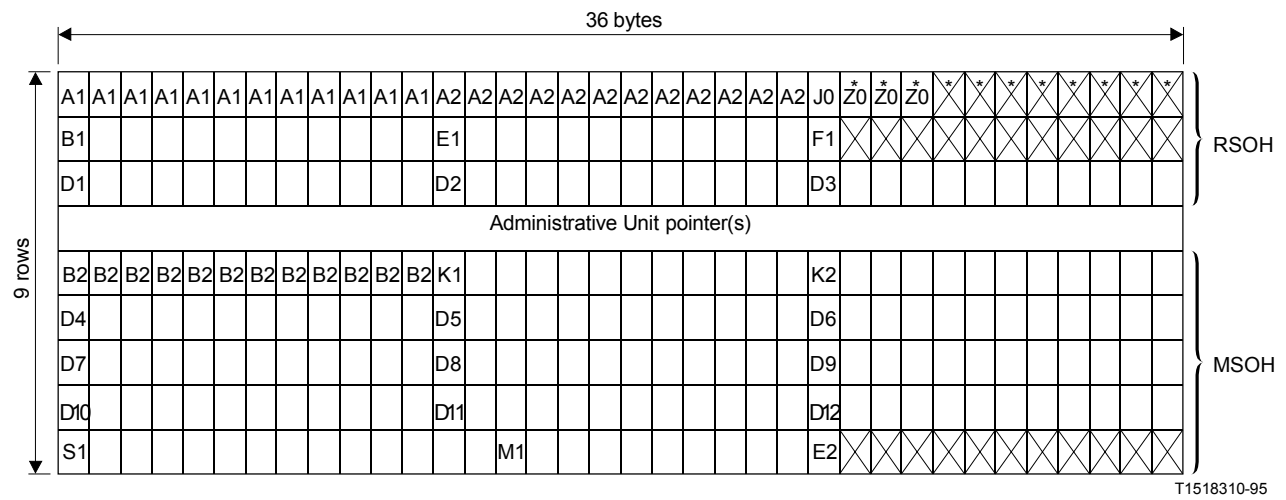

- X Bytes reserved for national use
- * Unscrambled bytes. Therefore care should be taken with their content

NOTE – All unmarked bytes are reserved for future international standardization (for media dependent, additional national use and other purposes).

Figure 4

The unscrambled bytes of figure 4 can not be taken with their content but must be filled by “1” and “0” in alternance.

- Regarding the SOH bytes of the SDH leased line network interface, an overview of their functionalities is given in table 1. Just to be clear, the following definitions apply:
 - * **required:** these signals at the interface shall contain valid information as defined by ITU-T Recommendation G.707.
 - * **optional:** valid information may or may not be present in these signals; as a consequence, the use of these functions shall be mutually agreed by the customer and Belgacom.
 - * **not applicable:** this function is not defined at the interface; as a consequence, the customer's terminal and the SDH leased line NTP have to be capable of functioning properly with an incoming STM-4 signal programmed with this “undefined” SOH byte.

SOH-byte	functionality requirement	Remarks
A1-A2	required	
JO	optional	By mutual agreement between Belgacom and the customer a Section Access Point Identifier may be used, conform to ITU-T Recommendation G.707.
B1	required	
E1, E2	not applicable	
F1	not applicable	
D1-D12	not applicable	
B2	required	
K1 & K2(bits 1-5)	not applicable	Required if APS (MSP) is provided
K2(bits 6-8)	required	MS-RDI is used for MS-FERF and MS-AIS.
S1 (bits 5-8)	required	
M1	optional	
other bytes	not applicable	

Table 1

3.3. Path layer functions

- The path layer forms the end-to-end connection of the SDH leased line. Two types of VCs are offered by the Belgacom STM-4 and VC-4-4c leased line services, namely: VC-4, and VC-4-4c. The formats of these VCs are defined in ITU-T Recommendation G.707. Each VC-n includes a payload and a path overhead (POH).
- Please note that the path overhead of a VC-n, transmitted across the SDH leased line connection, has to be generated and terminated by the customer's terminal equipment. The Belgacom SDH leased line shall transport these virtual containers *transparently, except the network operator byte N1*:
 - ⇒ The N1-byte could be used by Belgacom to determine the quality of the received and transmitted VC-4 path signals. The content of the B3-byte may change at the Belgacom tandem connection monitoring processes; however, the integrity of the parity information of the B3-byte will be maintained through the Belgacom SDH leased line.

3.4. Safety

The SDH leased line NTP complies with the requirements for accessible parts of a SELV circuit (in accordance with EN 60950).

3.5. ElectroMagnetic Compatibility (EMC)

The NTP complies with the EMC requirements which are imposed under the EMC Directive (89/336/EEC).

3.6. TU/VC numbering scheme

The numbering scheme must be compliant to G.707.

The customer and Belgacom have to use the above mentioned numbering scheme for his VC-n address, which has to be communicated to Belgacom. By doing so, Belgacom will be able to offer the customer an enhanced service for his STM-4 and VC-4-4c leased line services.

4. Terminal equipment

The technical characteristics of the customer's terminal interface have to be in line with the relevant ETSI and ITU-T specifications and recommendations.

At the NTP the customer shall provide Belgacom with a grounding connection point. This grounding connection point should be easily accessible, located near the NTP, and shall enable Belgacom to attach a 4 mm² (minimum section) ground cable with lug, bolt and washer. The characteristics of the grounding connection point provided by the customer must be conform to article 69 of the actual RGIE¹; this grounding point shall have a resistance value not exceeding 30 Ohms.

¹ RGIE: Règlement Général des Installations Electriques

ANNEX 1

Abbreviations

For the purpose of this document, the following abbreviations apply:

AIS	Alarm Indication Signal.
AU-n	Administrative Unit, level n.
AU-4-AIS	Administrative Unit (level 4) Alarm Indication Signal.
BBE	Background Block Errors.
BIP-N	Bit Interleaved Parity, width N.
EMC	ElectroMagnetic Compatibility.
ES	Errored Second.
ETS	European Telecommunication Standard.
ETSI	European Telecommunications Standards Institute.
ITU-T	International Telecommunication Union.
MS-AIS	Multiplex Section Alarm Indication Signal.
MS-FERF	Multiplex Section Far End Receive Failure.
MS-RDI	Multiplex Section Remote Defect Indication.
MSOH	Multiplex Section OverHead.
NTP	Network Termination Point.
PDH	Plesiochronous Digital Hierarchy.
POH	Path Overhead.
Ppm	Parts per million.
RGIE	Réglement Général des Installations Electriques
RSOH	Regenerator Section OverHead.
SDH	Synchronous Digital Hierarchy.
SELV	Safety Extra Low Voltage.
SES	Severely Errored Second.
SOH	Section Overhead.
STM-N	Synchronous Transport Module, level N.
TUG-m	Tributary Unit Group, level m.
TU-m	Tributary Unit, level m.
TU-m-AIS	Tributary Unit, level m, Alarm Indication Signal.
VC-n	Virtual Container, level n.

ANNEX 2

Reference list of standards

G.703	(11/2001) Physical/electrical characteristics of hierarchical digital interfaces.
G.707	(3/1996) Network node interface for the synchronous digital hierarchy (SDH).
G.783	(3/2001) Characteristics of synchronous digital hierarchy (SDH) equipment functional blocks.
G.825	(3/2000) The control of jitter and wander within digital networks which are based on the synchronous digital hierarchy (SDH).
G.826	(2/1999 & 7/2001) Error performance parameters and objectives for international constant bit rate digital paths at or above the primary rate.
G.957	(6/1999) Optical interfaces for equipment and systems relating to the synchronous digital hierarchy (SDH).
prETS 300 147	(11/96) Transmission and Multiplexing (TM); Synchronous Digital Hierarchy (SDH); Multiplexing structure.
ETS 300 166	(1993) Transmission and Multiplexing (TM); Physical and electrical characteristics of hierarchical digital interfaces for equipment using the 2048kbit/s based plesiochronous or synchronous digital hierarchies.
ETS 300 417-1-1	(1996) Transmission and Multiplexing (TM); Generic functional requirements for Synchronous Digital Hierarchy (SDH) equipment, part 1: Generic processes and performance.
ETS 300 417-2-1	(1996) Transmission and Multiplexing (TM); Generic functional requirements for Synchronous Digital Hierarchy (SDH) equipment, part 2 : Physical section layer functions.
ETS 300 417-3-1	(1997) Transmission and Multiplexing (TM); Generic requirements of transport functionality of equipment; Part 3-1: Synchronous Transport Module-N (STM-N) regenerator and multiplex section layer functions.
ETS 300 417-4-1	(1997) Transmission and Multiplexing (TM); Generic requirements of transport functionality of equipment; Part 4-1: Synchronous Digital Hierarchy (SDH) path layer functions.
IEC 169-13	(1976) Radio frequency connectors - part 13; R.F. coaxial connectors with inner diameter of outer conductoe 5.6 mm – Characteristic impedance 75 ohms (Type 1.6/5.6)
IEC 874-13	(1993) Connectors for optical fibres and cables - part 13: sectional specification for fibre optic connector - type CF08.
EN 60950	(1992) Safety of information technology equipment including electrical equipment.